

# LIFT FRAME

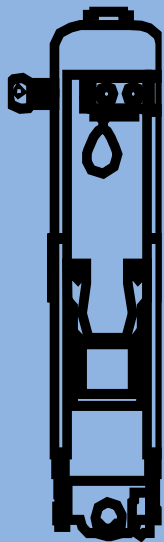

## OVERVIEW

The DWELLOP Lift Frame is designed for greater safety and working environment during coiled tubing operations on floating platforms. The Lift Frame is built with the same high standards as the rest of DWELLOP product line.

The Lift Frame Elevating Table is operated with synchronized screws allowing the Table to be operated with great precision and safety.

The Tool Winch as mounted on a pivoting arm, making smooth pick-up from Rig floor, and hitting well centre exact.



## KEY NUMBERS

- ❖ Up to 750 ton tension
- ❖ SWL: 20 tons
- ❖ 18 ton main winch
- ❖ 2 ton tool winch
- ❖ 3 ton stabbing winch
- ❖ Injector elevation table
- ❖ Injector tilting
- ❖ Injector skidding

IMPROVED WORKING ENVIRONMENT

IMPROVED RIG-UP AND DOWN TIME

IMPROVED OPERATIONAL EFFICIENCY



KOPPHOLEN 25

4313 SANDNES

NORWAY



+47 51 57 28 00



SALES@DWELLOP.NO

# LIFT FRAME

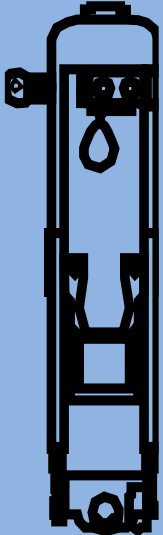

## OPTIONS

- ❖ Injector goose neck staircase
- ❖ Hydraulic injector slewing
- ❖ Stainless steel fittings
- ❖ Gin Pole with 3 ton tugger winch
- ❖ BOP Platform
- ❖ 3 ton Stabbing winch for pulling and stabbing coil
- ❖ Shipping Basket for secure transport
- ❖ Injector elevation table – travel window up to full length of frame
- ❖ Injector tilting – hydraulic spears for aligning the coil prior to tool make-up
- ❖ Injector skidding – brings the injector off well, allowing tool and BHA change

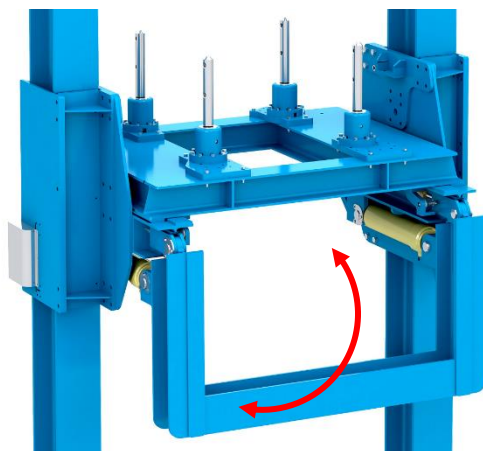

KOPPHOLEN 25

4313 SANDNES

NORWAY



+47 51 57 28 00



SALES@DWELLOP.NO